

GRAVELLY®

**424
430
432**

**OWNER'S
MANUAL**

 **GRAVELLY**
CORPORATION

A SUBSIDIARY OF STUDEBAKER-WORTHINGTON, INC.

CLEMMONS, N.C. 27012



THANK YOU for your investment in Gravely equipment. It is an investment, for the Gravely will save you work and worry for many years.

You will gain still greater satisfaction from your powerful Gravely if you add the tools you need for your other jobs. From time to time we suggest you consult our four-color catalog or this manual for the many Gravely attachments that will eliminate grounds upkeep and garden drudgery.

Numerous independent dealers and factory branches distribute Gravely equipment. All are ready to give prompt and efficient service, with parts in stock and personnel trained in factory-service methods.

Your Gravely Tractor and attachments are warranted under terms shown herein. To qualify for this Warranty, you must register your equipment by completing the attached Registration Card and returning it. For your own protection, please do this right away.

SAFETY PRECAUTIONS

IT IS TOO LATE TO REMEMBER WHAT SHOULD HAVE BEEN DONE AFTER THE ACCIDENT HAS HAPPENED. Many hours of lost time and much suffering can be caused by the failure to practice simple safety rules.

1. Make sure the work area is clear of objects that might be picked up and thrown.
2. Do not let anyone who isn't familiar with the controls operate the tractor.
3. Do not wear loose fitting clothes that might get caught in moving parts.
4. Disengage all clutches prior to starting the engine.
5. Do not carry passengers on the tractor or its attachments.
6. Always disengage the attachment drive when you leave the operator's position.
7. Do not try to operate the tractor when you are not in the operator's position.
8. Keep controls in proper adjustment.
9. Operate slowly enough on curves or slopes so that there is no danger of tipping.
10. Do not operate too close to the edge of a ditch or creek and watch for hidden hazards.
11. Keep tractor in gear when going downhill.
12. Do not add fuel to the tractor while it is running, or while you are smoking.
13. Never run the engine in a closed garage or shed.
14. Keep all shields and guards in place while the tractor is running.
15. Do not try to oil or grease the tractor or its attachments while in operation.
16. Do not leave the operator's position while the tractor is moving.
17. Shut off the engine before attempting any adjustments or repairs.
18. Do not direct the discharge of material toward bystanders or buildings.
19. Never shift the Range Selection Lever while the tractor is moving. Always come to a complete stop prior to shifting.
20. Never shift the Range Selection Lever while stopped on a hill.

TABLE OF CONTENTS

Safety Precautions	2
Introduction	4
Lubrication & Maintenance	6
Controls	7
Operation	8
Attaching Attachments	9
Attachment Chart	13
Attachments	14
Manufacturer's Specifications & Recommendations	16

Engine 10W30
Transmission = 90W high oil



FIGURE 1

INTRODUCTION

One of the great engineering teams of the industry designed the Gravely 4 wheel tractors for you — literally “from the ground up.” It’s pure fun to do your tough jobs with this sure-footed tractor—the easy jobs with effortless perfection.

Enjoy solid comfort while you steer the sturdy, deep-framed Gravely through a four-season series of tasks. Be amazed at the maneuverability, the instant control.

Instant control because one lever gives you forward, neutral or reverse. Flip another lever—cut ground speed in half, while attachment speed stays the same. Great for heavy mowing, snowblowing, the jobs that take geared-down power.

Tackle the tough ones with real confidence because the Gravely has true all-gear-drive; all the way from the engine crankshaft to and through the transmission, to the attachment.

Power that flows smoothly from a high torque Gravely engine . . . practically vibrationless, power that goes right to the job through steel shafts, gears and universal joints. No belts, no chains. Smooth, steady, dependable power.

Big, safety-designed footrests let you relax while you ride in a comfortably padded, spring-loaded seat. No fumbling or fancy footwork required, either—the control console is grouped conveniently at hand.

Truly the most stable ride because the Gravely was designed with tractionized power. Engine and transmission are over the rear wheels. Maximum traction, maximum effective use of the engine power . . . and a low center of gravity that gives amazing performance, a stable ride, even on steep slopes!

Steering and maneuvering are quick and easy . . . and the Gravely boasts a small equal turning radius, left and right, easy and precise.

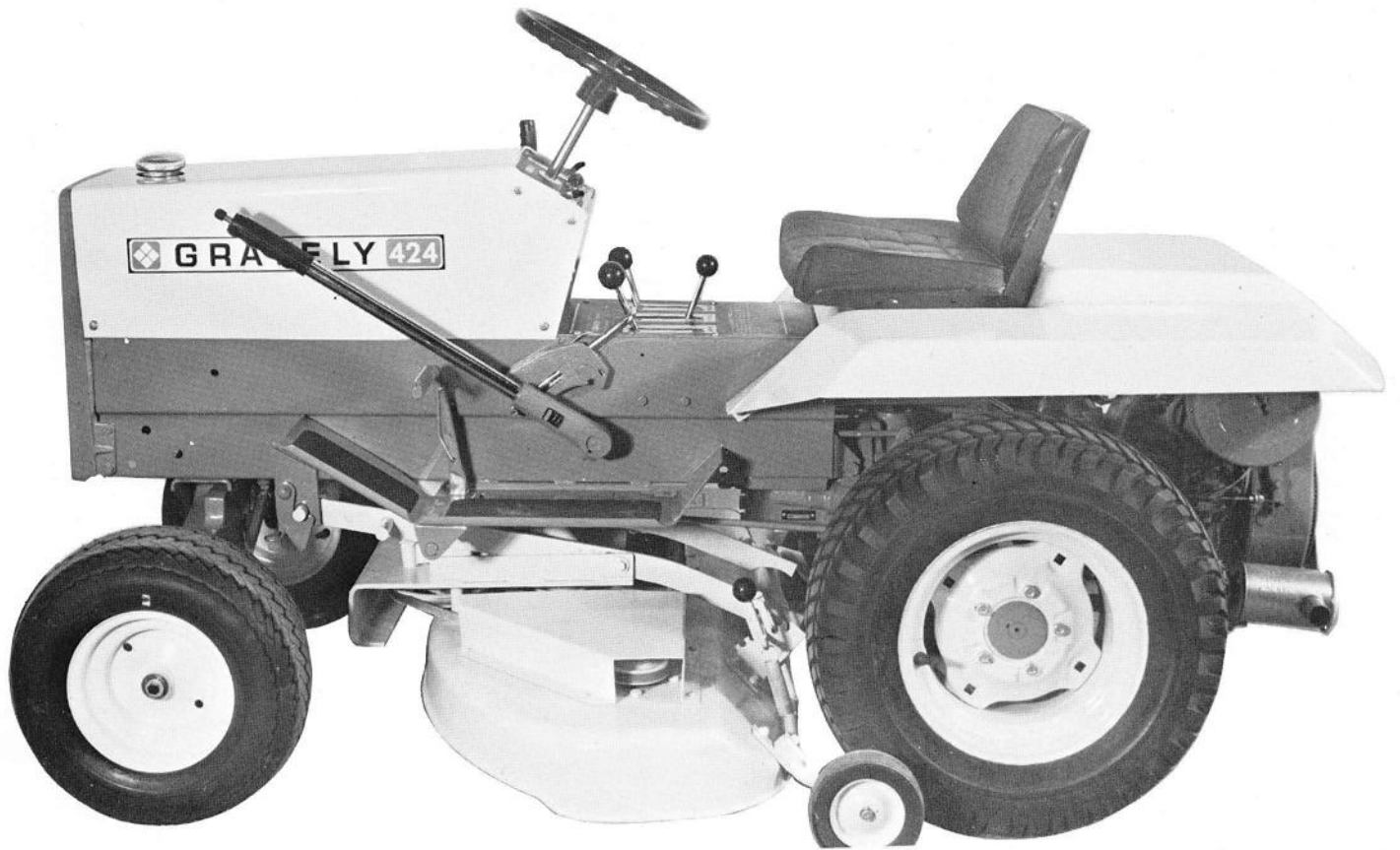

FIGURE 2

Gravelly designed the 4 wheel tractors to mount and drive implements where the implement does the job best: in front, underneath or trailing. Implements lift with one common lever. Can be held in any position by a positive lock.

Attachments are easily changed. Just a twist of the wrist. Steel shafts and universals drive Gravelly power implements. Connect and disconnect with a twist of the wrist. Mounting is by simple rugged latches and lockpins.

Gravelly 4 wheel tractors are available in three models:

424	10 HP
430	12 HP
432	14 HP

Your Gravelly tractor will give long years of highly satisfactory performance if maintained and operated as outlined in this manual.

It is important that you know the serial number of the tractor. It is located on the advance casting. It is _____ . Also, it is important that you know the model number and serial number of the engine. It is model number _____ , and serial number _____ .

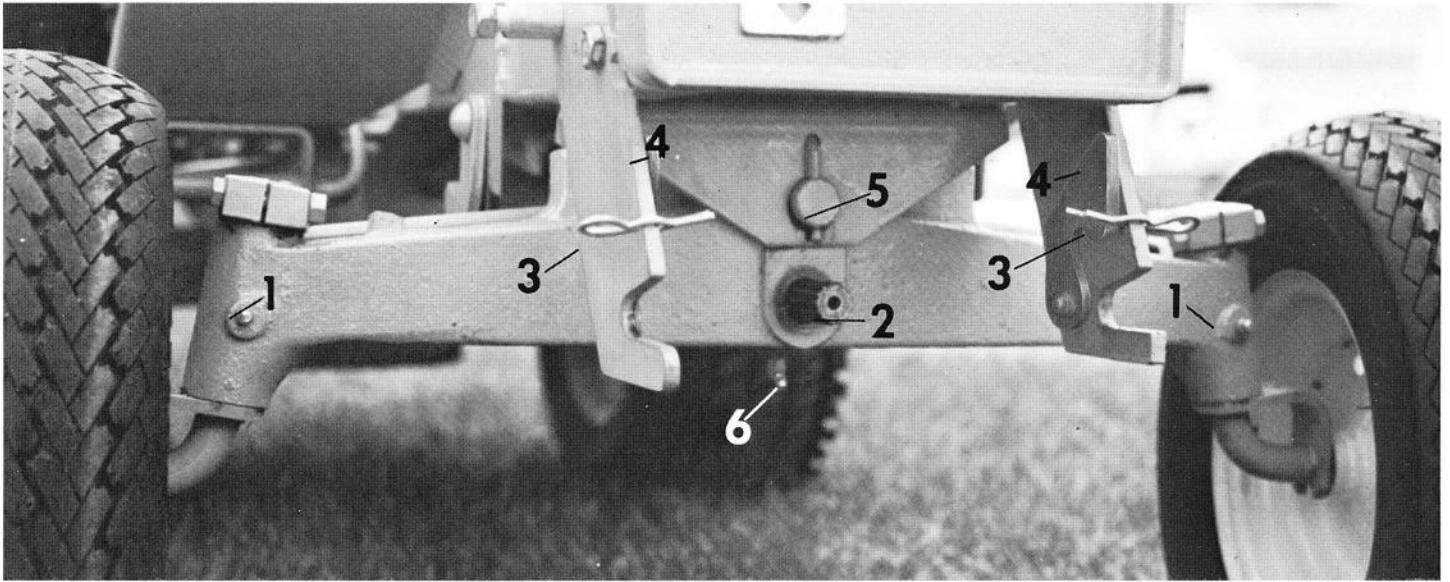

FIGURE 3

LUBRICATION and MAINTENANCE

Lubrication

Transmission—capacity 5 U.S. quarts. Use multi-purpose gear lubricant 90 W-EP only for year-round operation.

Engine

Capacity—5 U.S. pints. Use API classification MS oil SAE 30 above 0°F. and SAE 5W20 below 0°.

Daily check oil level in engine and transmission. Maintain oil levels at full marks on both dip sticks. Do not overfill. Change engine oil every 25 operating hours or oftener under dusty conditions. Drain plug is located on the lower RH side of the engine base. Transmission drain plug is the lowest axle housing bolt on the LH axle housing.

Maintenance

Daily check oil levels in engine and transmission and check fuel supply. Every oil change, grease the tractor.

The linkage of the forward-reverse lever and the T-2 gear lever can be adjusted to suit the operator; however, be sure that the linkage does latch overcenter.

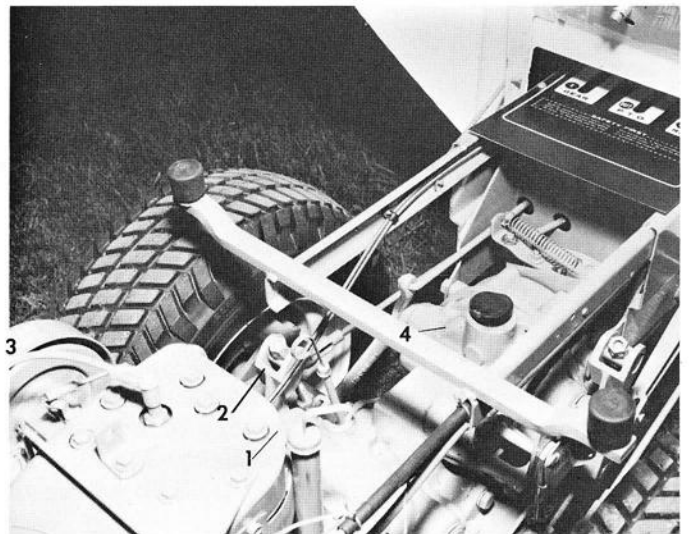

FIGURE 4

Air Cleaner

The air cleaner cartridge should be cleaned by gently tapping on a flat surface. Be sure the cartridge fits the bottom adapter plate and the wing nut on the top adapter is finger tight. Replace the cartridge if bent, crushed, or damaged in any way. Clean or replace cartridge when necessary. A loss of power is an indication that air cleaner service is required. Be sure brass washer is in place under wing nut.

Tires

Proper tire pressure is 12 psi; check regularly.

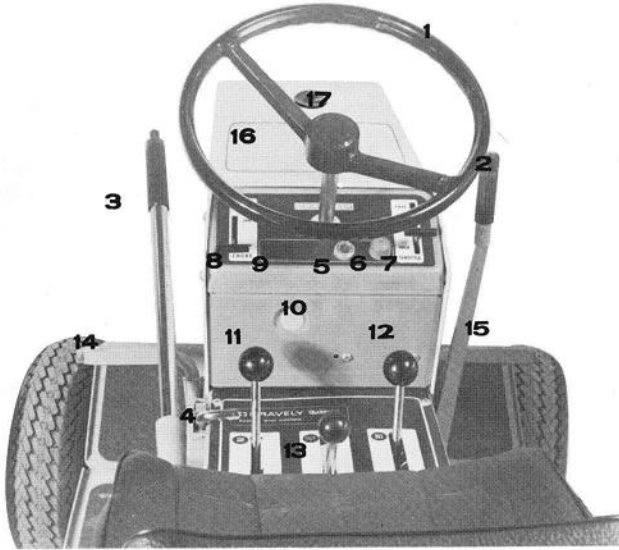

FIGURE 5

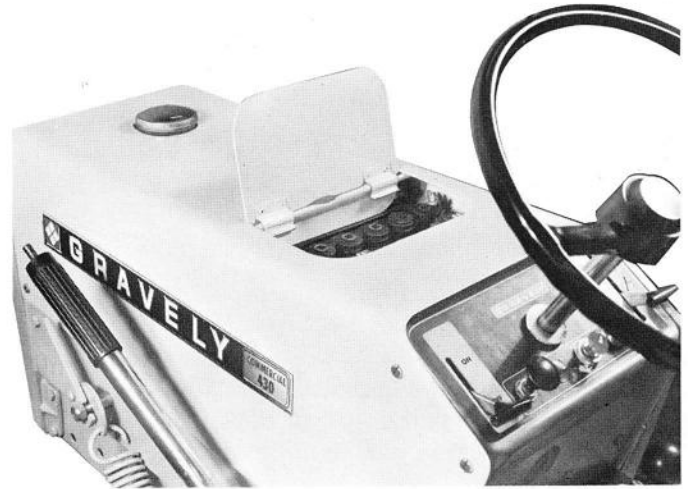

FIGURE 6

CONTROLS

1. Steering Wheel.
2. Forward-Reverse Lever—Push away from you to go forward, pull toward you to back up.
3. Attachment Lift Lever—raise to raise the attachment, lower to lower the attachment.
4. Attachment Lift Position Lock—use to lock the attachment lift in position.
5. Key switch—ON-clockwise; OFF-counter clockwise.
6. Starter Button—push to start engine after key switch is on; release as soon as engine fires.

CAUTION: Do not hold depressed over 15 seconds without allowing cooling period for starting motor.
7. Choke—Move lever to “ON” position when starting, move toward “OFF” position as engine warms up.
8. Throttle.

9. Light Switch.
10. Cigar lighter.
11. Gear Selector Lever—Controls ground speed and attachment speed. It can be moved while tractor is in motion.
12. Swiftamatic 8 Range Selector Lever — Controls ground speed only, Low Range is 50% of high range. It does not affect attachment R.P.M.

CAUTION: Do not move this lever while the tractor is in motion.
13. PTO Lever—engages or disengages the attachment drive.
14. LH Brake—when applied, brakes the left rear wheel.
15. RH Brake—when applied, brakes the right rear wheel.
16. Door—opens to battery to check electrolyte level.
17. Fuel tank cap—opens to fuel tank; capacity, 5 gallons.

OPERATION

Before Starting

1. Be sure the fuel tank has been filled. Use any good regular fuel. The fuel tank holds 5.0 U.S. gallons.
2. Check BOTH oil levels. See figure 4. The Transmission oil level is checked by 2 on Figure 4, the Engine oil level by 1 on Figure 4. Be sure oil is to the full mark on each dip-stick when the tractor is level.

CAUTION: Do not overfill.

3. P.T.O. Control in the "OUT" position, "Gear" lever in center (Vertical) position. The Forward and Reverse Control Handle, must be in the Neutral position, which is vertical in relation to the ground.

Starting the Tractor

With the Gear Control in Neutral position, and Forward and Reverse Control Handle in Neutral position; Range Control Handle in "LO", P.T.O. in OUT position:

1. Move Choke Lever (7, Figure 5) from "OFF" position to "ON" position.
2. Move Throttle Control (8, Figure 5) to approximately halfway between "Idle" and "Fast" position.
3. Turn Ignition Key (5, Figure 5) to ON position, which is clockwise. NOTE: THIS IS NOT A STARTER-IGNITION KEY. IT IS A SAFETY FEATURE. STOP WHEN IGNITION KEY MEETS RESISTANCE.
4. Press Starter Button, (6, Figure 5). Do not hold depressed more than 30 seconds.
5. As soon as engine fires, release starter button, and begin slowly moving Choke towards the "OFF" position as engine warms up.

The Swiftamatic 8 Control, (12, Figure 5) pre-selects the range you desire, either "Hi" or "Lo" Range.

The effect of the Swiftamatic 8 is to select the basic ratio of ground speed. When the Lever is in "Hi" position, this gives maximum ground speed. When in "Lo", it reduces the ground speed one-half, BUT ATTACHMENT SPEED REMAINS THE SAME.

ALWAYS SELECT THE GROUND SPEED WHEN TRACTOR IS STOPPED, AND BRAKE (14 & 15, Figure 5) ON.

NEVER ATTEMPT TO CHANGE THIS LEVER WHILE TRACTOR IS IN MOTION.

ENGAGING ATTACHMENTS

Assuming the use of a **power** Attachment, reduce engine speed. Then put the attachment in Gear by using the P.T.O. lever. Move from "OUT" to "IN" position. If no power attachment is used, P.T.O. Lever should be in "OUT" position.

Refer to Figure 5. The left hand control, labeled "GEAR" is the lever which selects high and low gear. Number 1 is the low gear, number 2 the high gear.

Select the gear you desire by moving the "GEAR" lever GRADUALLY from its neutral, (vertical) position to either "1" or "2". Complete the movement until it "locks" in gear. If engine begins to choke down while moving the gear lever, increase the engine speed.

STARTING TRACTOR MOVEMENT

You are now ready to start forward or reverse motion. This is controlled instantly, by the unique Forward and Reverse Handle, (2, Figure 5).

To go forward, push handle forward (away from you) gradually until it "locks" in forward. To reverse, pull handle backward toward you until it locks. To stop the Tractor motion, move handle to neutral (vertical) position and apply the brake.

THIS LEVER GIVES YOU INSTANT CONTROL OF THE MOTION OF THE TRACTOR. IT IS ALSO USED AS A BRAKE . . . for example, if you are going forward and need to make an instant stop, simply pull lever through neutral and exert necessary pressure in the Reverse direction (but do not lock in gear), and Tractor will stop instantly. The same method may be used in Reverse, by moving the lever through neutral and exerting pressure in the forward direction.

TO STOP THE TRACTOR

Bring Forward and Reverse Handle to Neutral (Vertical), and apply brake.

Put P.T.O. Lever in "OUT" position.

Move throttle to "Idle."

Turn Ignition Key counter-clockwise.

CAUTION: Never leave Tractor when it is running. Stop, and take ignition key out. Never work, adjust, or approach any power attachment without disengaging P.T.O. Lever (moving to OUT position), stopping Tractor and engine, and removing ignition key. Be sure attachment has stopped all movement.

ATTACHING ATTACHMENTS

Any Gravely Attachment listed may be used with excellent results.

There are three types: Center-mounted, Frontmounted, and Trail-Behind. The necessary attaching kits are shown on the chart on the succeeding pages.

50 INCH UNDERSLUNG ROTARY MOWER

Attachment Kit Required: None

Optional Kit Recommended: Lift Assist

Place the 50 inch Rotary Mower centered in front of the Tractor, with Gauge Wheels towards the tractor.

Be sure the Gauge Wheels (1, Figure 7) are set in their lowest position. See Figure 7, the illustration shows proper setting.

The Drive Shaft must be lined up straight with drive housing. If Lift Assist Kit is used, attach the Springs (2, Figure 7) to the Spring Brackets (3, Figure 7), so the Latch (4, Figure 7) is to the outside. Lay them to the front and slightly in towards each other, so they will not interfere when the Tractor Wheels run over the mower.

The Pivot Lift Rod, Pivot and Ball Joint Assembly (5, Figure 7) is assembled to the Tractor as the next step.

There is one adjustment on the Lift Rod which is made once, on the initial attachment of the 50 inch Rotary Mower.

You will see two jam nuts at one end of the assembly. If locked, loosen them, and run them to within approximately two inches of the end of the Pivot Rod. Do not lock.

Be sure the Attachment Lift Lever is all the way down, and the Attachment Position Lock is in its lowest position. The Attachment Lift Lever is operated by depressing the button on the top of the Handle Grip, and moving it all the way forward. The Position Lock is operated by lifting it up against the Spring, and sliding it down and forward to its lowest position. See Figure 7.

Grasp the Pivot, and turn the Rod so the Ball Joint Assembly (Locking Ring and Spring) is up. Amidship of the Tractor, underneath, and to the right there is a strap with five tear-drop holes in it. (See Figure 8).

Insert the protruding end of the Pivot into the **SECOND HOLE FROM THE BOTTOM**. When in place, turn the Rod over so the Ball Joint is down.

Next, start the tractor, and drive directly over the 50 inch Rotary Mower Attachment, positioning the Tractor so the lead edge of the Rear Tire is approximately lined up with the forward edge of the steel rim of the Gauge Wheels, and centered over the Mower.

STOP THE TRACTOR and remove the Ignition Key.

It is helpful to have the forward edge of Mower raised when attaching. Grasp the deck at the Chute and lift, inserting a block approximately four inches high at the center of the leading edge of the mower (towards the front of the Tractor). You may place the block before driving over the attachment, if desired.

Now from the right side of the Tractor, grasp the Lift Rod with the left hand, and the locking ring on the Ball Joint assembly with your right. Lift locking ring up, and push the opening exposed over the Ball parallel to the Mower Deck. Release locking ring.

Be sure the Attachment Latches (9, Figure 7) are open. Then begin raising the Mower by the Attachment Lift Handle until the Attaching Shaft (10, Figure 7) is almost ready to slip into the Brackets. Use the Attachment Position Lock to hold the Mower in this position. (Raise Position Lock (8, Figure 7) against the spring, and pull up and towards the rear until it is seated against the Attachment Lift Lever. Release both.

Grasp the Attaching Shaft and raise, seating the protruding part of the Shaft in the latch notch, and close latch. Insert Hair-Pin Cotter Key to hold latch closed. Repeat the operation on the other side. Then discard the four inch block.

Release the Attachment Lift Handle and the Attachment Lift Position Lock, letting the Mower go all the way back to the ground. Normally, the entire drive shaft will be assembled . . . that is the shaft permanently attached to the Mower Drive Housing, and the square tube shaft with the universal joint and locking ring on the other end. If not assembled, slide the Square Tube in the shaft.

Grasp the universal Joint (11, Figure 7) with one hand, the Locking Ring (12, Figure 7) with the other. Turn the Locking Ring, insert over the spline, and release. Check to be sure it is in place.

To complete the one and only adjustment of the Lift Rod, attempt to raise the Mower until the Attachment Lift Lever locks in place at the highest position. If it **DOES NOT** lock run the jam nuts upward until the mow-



FIGURE 7

1—Gauge Wheels. 2—Assist Spring. 3—Spring Bracket. 4—Latch. 5—Lift Rod. 6—Attachment Lift Handle Button. 7—Attachment Lift Handle. 8—Lift Position

Lock. 9—Latch. 10—Latch Pin. 11—Universal Joint. 12—Lock Ring. 13—Pivot Arm. 14—Gear Housing Support Weldment. 15—Latch Pin. 16—Height Adjusting Bracket. 17—Height Adjusting Handle.

er will lock in the high position. To do this, it is necessary to drop the mower again to change the nut positions. When properly adjusted, the mower locks in the high lift position, the deck is parallel, the Pivot Arm (13, Figure 7) is flush with the Gear Housing Support Weldment (14, Figure 7), and the Mower is within about ¼ inch of the frame amidships. After adjustment is reached, lock

jam nuts on the Pivot Lift Rod.

With the Mower raised to its highest position, and Attachment Lift Assist Springs attached to their Brackets (See Figure 7), turn latch until half-moon cutout is exposed, and bring half-moon cutout to the latch pin (15, Figure 7), and snap the latch in place. Do the same on the other side. Latches are always to the **outside**.

The Mower is now ready to perform. Although these instructions are detailed, you will find that you can put the 50" Rotary Mower on and take it off in less than three minutes, without tools, once the sequence is learned.

To remove, reverse the sequence: unsnap and remove Assist Kit, with mower in raised position.

Drop mower to the ground with Attachment Handle. Unlock Ring from P.T.O. spline. Raise Lift Lever Locking Ring and pull from Ball. Remove Hairpin Cotter Keys and unsnap attaching latches.

With P.T.O. in OUT position, drive tractor over mower IN REVERSE. Stop tractor and remove Attachment Lift Rod.

LUBRICATION

There are four Alemite Fittings on the 50" Rotary Mower: Three on the spindles under the deck, and one on the Driveshaft on the right side. These should be greased every eight use-hours.

The Gear Housing is filled with a good grade of general purpose grease. The housing cover should be removed periodically for checking.

Commercial Use: every 160 hours.

Homeowner Use: annually.

HEIGHT ADJUSTMENT

The 50" Rotary Mower cuts from 1¼ inches to 3¾". There are five notches in the height adjustment Bracket (16, Figure 7). To adjust height, raise mower with Implement Lift Lever, Pull Height Adjustment Control (17, Figure 7) up and move to the notch desired. Drop Mower again.

The Mower may also be operated at other heights, up to its highest position on the Attachment Lift. To set heights above the Adjusting Control Capacity, use the At-

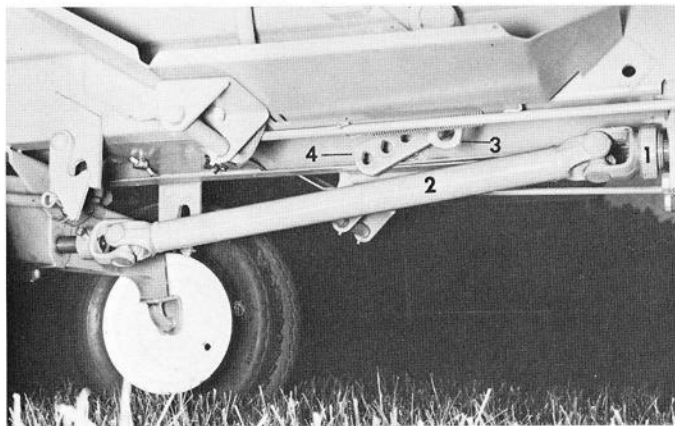

FIGURE 8

1—Locking Ring. 2—Drive Shaft Assembly. 3—Attachment Lift Arm for front Mounted Attachments. 4—Attachment Lift Arm for Center Mounted Attachments.

tachment Lift Handle and the Position Lock.

MOUNTING FRONT MOUNTED ATTACHMENTS

Required: Front Drive and Adapter Kit as shown on Attachment Chart.

Recommended: Spring Assist Kit.

Most front-mounted attachments currently available for the Gravely mount as follows:

Mount the Gear Housing to the adapter Weldment (1, Figure 9). There are two studs on the face of the Gear Housing, these go in the holes in the weldment **opposite** the protruding strap.

Mount the two studs protruding through the weldment to the top two holes of the Swivel Casting (2, Figure 9) on the front mounted attachment. (40" Rotary Mower Illustrated). Mount the Spring Bracket as shown, (3, Figure 9).

There is a "Dog Clutch" in the attachment Safety Clutch which must engage a "Dog" in the Gear Housing. When mounting to the attachment, it may be necessary to turn the stub shaft on the rear of the Gear Housing until they mesh. Then put the nuts (4, Figure 9) on the studs and insert the bolts in the bottom two holes, and tighten.

Next step is mounting the Drive Shaft Assembly to the Tractor. This is a long shaft with a universal joint and locking ring on one end, and a spline on the other. See Figure 8.

First, remove the Plastic Caps from the bottom center hole of the tractor front axle. Keep the Caps, replace when Prop Shaft is removed. (2, Figure 3). Insert the splined end of the shaft through the hole. Give the Alemite Fitting under the hole two or three shots of general purpose grease.

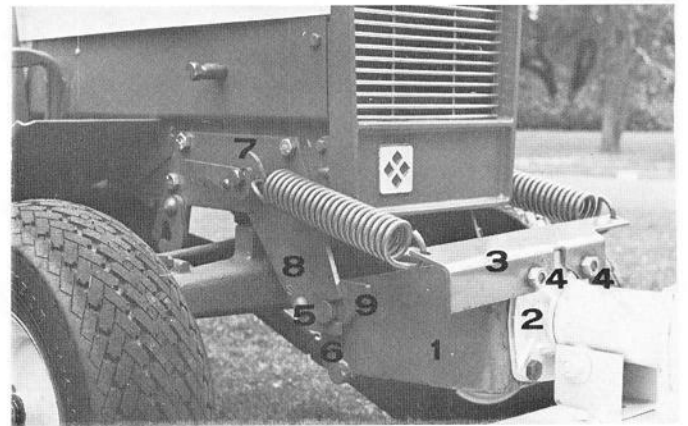

FIGURE 9

1—Adapter Weldment. 2—Swivel Casting. 3—Spring Bracket. 4—Studs and Nuts. 5—Attaching Pins. 6—Latch Plate Lip. 7—Spring Latch. 8—Front Attachment Brackets (See Note). 9—Latch.

Attach the other end of the Prop Shaft by means of the Universal Joint and Locking Ring to the Stub Shaft protruding from the Transmission. Holding the Universal, turn the Locking Ring, insert on spline and release. Check to be sure it is seated.

There are two Attaching Pins on the Adapter Weld- until you can just hang the attachment on the lower lip of the slot in the bracket. (9, Figure 9).

Attach the double-universal joint by starting it over the Prop Shaft Spline, and over the Stub Spline in the Gear Housing. Once these are started, then just move the entire attachment back until the Pins bottom on the slot. Close Latches and insert Hairpin Cotter Keys.

Now attach the Attachment Lift Mechanism. On the left side of the tractor, underneath, there is a strap extending downward with **two** holes in it. Attach the Push Rod Guide Weldment to one of the two holes, and secure with Hairpin Cotter Key, the round bar extension goes toward the front of the tractor.

(Most attachments will use the bottom hole because this gives full lift. Certain attachments, because of their construction, cannot be raised as high because they will interfere with the tractor grill. These are the Snowblower and Sprayer, which use the top hole.)

Next, slip the open end of the Push Rod Weldment over the bar, and attach the other end by means of the stud to the Strap extending downward from the Adapter Weldment, and secure with Hairpin Cotter Key.

Attach the Springs and Latches as shown in Figure with Attachment lifted to high position. Be sure you install so latches (7, Figure 9) are on the outside, as shown.

*(Note: Front Attachment Brackets (8, Figure 9) are part of the Front Drive Kit. They must be attached **before** any of the above steps are taken. Install by bolts and nuts provided.)

When using Lift Assist Kit, top bolts and nuts must be removed and replaced with Latch Pins and Nuts included in Lift Assist Kit.

Mounting the Front Mounted Snowblower and Snowblade: Instructions for mounting the Snowblower and Snowblade to the tractor are furnished with each of these attachments.

MOUNTING TRAIL BEHIND ATTACHMENTS

Required: Trail-Behind Attachment Kit.

The Gravelly is equipped with a Rear Hitch that can accept Clevis Pin hitches or the standard Gravelly Rear Hitches.

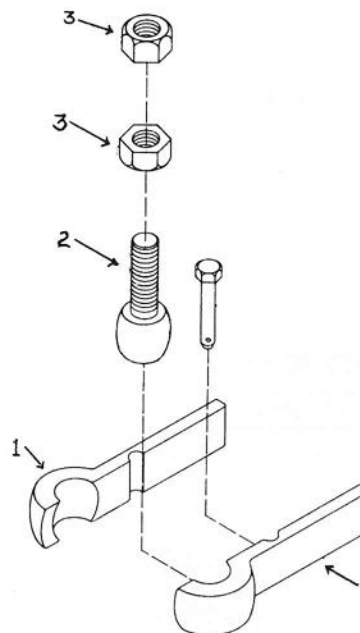

FIGURE 10

1—Rear Hitch. 2—Ball Stud. 3—Jam Nuts.

For Gravelly Attachments, the kit consists of two Split Sockets, a Pin, a Ball Stud and two Nuts.

To attach, thread one nut on the Ball Stud as far as it will go. Insert Ball Stud through the hole in the Rear Hitch from the bottom (See Figure 10) until sufficient thread is showing to accept the other nut. Tighten bottom and top nut towards the hitch, locking Ball Stud securely in place.

To attach trail-behind attachments, place Split Sockets around Ball Stud, insert shanks into pipe opening on attachment, line up holes and drop pin in place. To disassemble, pull pin and pull attachment back to release Split Socket.

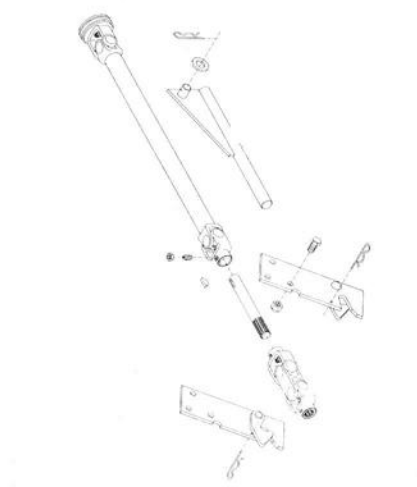
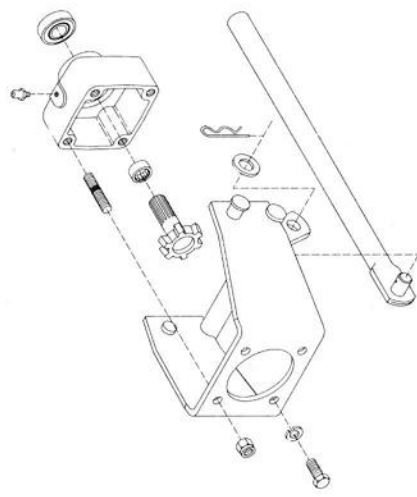
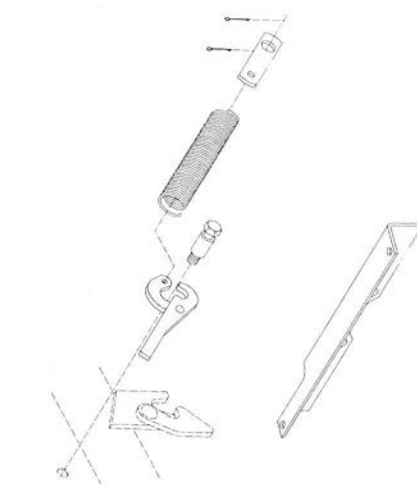
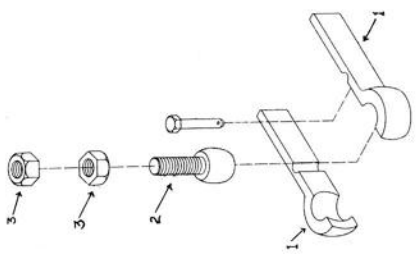

Attachments for 424, 430 and 432 Tractors

MA No.	Attachment	Front Drive Kit	Front Adapter Kit	Lift Assist Kit	Trailing Hitch Kit
MA 600	40" Rotary Mower	Required	Required	Recommended	Not Required
MA 606	40" Commercial Mower	Required	Required	Recommended	Not Required
MA 605	50" Rotary Mower, Underslung	Not Required	Not Required	Recommended	Not Required
MA 1203	Lawn Aerator	Not Required	Not Required	Not Used	Required
MA 403	Lawn Roller	Not Required	Not Required	Not Used	Required
MA 207	Seeder-Spreader, 5'	Not Required	Not Required	Not Used	Required
MA 1206	Sweeper, Lawn 30"	Not Required	Not Required	Not Used	Required
MA 300	Rotary Plow	Required	Required	Optional	Not Required
MA 1202	Shredder, Compost	Required	Required	Optional	Not Required
MA 209	Brush, Power	Required	Required	Recommended	Not Required
MA 213	Snowblower, 38"	Required	Not Required	Recommended	Not Required
MA 400	Cart, Steel	Not Required	Not Required	Not Used	Not Required
MA 709	22 Gallon Sprayer	Not Required	Not Required	Not Used	Required
MA 705	Power Take Off	Required	Required	Optional	Not Required
MA 706	Saw, 18" *	Required	Required	Optional	Not Required
MA 601	30" Rotary Mower	Required	Required	Optional	Not Required
MA 302	Cultivator, Rotary *	Required	Required	Optional	Not Required
MA 303	Cultivator, Toolholder *	Not Required	Required	Recommended	Not Required

* These attachments may be used on the Gravely 424, Gravely 430 and Gravely 432, but there are limitations; thus special techniques are required for efficient use. Consult your Gravely Dealer for complete information.

ATTACHMENTS

Rotary Plow

Gravely's exclusive Rotary Plow prepares a seedbed that's ready for planting when you finish plowing. Just one easy operation does it . . . without raking, discing, or other preparation.

The Rotary Plow employs a totally different—and unique—principle to give you a deep, mellow, even seedbed. The Plow's four high-carbon steel blades cut into the sides and bottom of the furrow 800 times a minute at normal working speed . . . actually turns the soil as it plows, with one of the four blades biting into the soil every half-inch.

Soil is pulverized from top to bottom of the furrow. The Rotary Plow mulches and works ground cover into soil evenly for greater humus content. In hard soil, the Plow goes to 7" depth . . . in soft soil to 10". Cuts a furrow up to 10" wide, depending on soil conditions. Makes a perfect seedbed without destroying the soil structure necessary for a productive garden.

Plowing with the Gravely 424, 430 or 432 is literally amazing. Implement lift makes handling at beginning and end of easy—the tremendous power of the high-torque Gravely 10, 12 and 14 HP engines almost loafs through the toughest plowing jobs. Use of steering wheel and brakes give you easy and precise control—and the plow is in front for visibility. Front drive and adapter kits required.

50" ROTARY MOWER

The Gravely 424 and the Gravely Commercial 430 or 432 power the rugged 50" centermounted Rotary Mower that gets the mowing job done in a hurry, while you go along for the ride.

With the deepest housing, greatest range of height adjustment (1½" to 5¾"), all gear-and-steel-shaft-drive right down to the single, self-adjusting belt that drives three off-set spindles, you do a mowing job that is the envy of the neighborhood. Adjust the mowing height from the seat, easily. Highlift blades, tremendously rugged housing and deck and the twist-of-the-wrist mounting, makes mowing the pleasure it ought to be.

For the rugged cutting lock the mower height with the position lock in an even higher position if you desire . . . mower keeps cutting with the same rugged efficiency.

Steel Cart

All-steel cart has about a ½ ton capacity. Sturdy, reinforced with a latch-release, self-dumping feature, the cart saves you a lot of time and backaches. 48" long, 30" wide, 1½" deep, with pneumatic tires, sturdy steel frame and axles.



40" ROTARY MOWER

Forty inches of mowing at a time lets you wind up the job fast. Big enough to get the big job quickly, and small enough to maneuver easily, so you trim as you go. Low height lets you get into the hard-to-get-places easily . . . and with Gravely you back out with a flip of the lever.

Anti-scalping skids, and casters. All-gear and splined steel shaft drive down to the staggered two spindle blades, to give a smooth cut. Deep housing to mulch and discharge even when the grass is tall.

Completely enclosed deck and drive for safety.



38" SNOWBLOWER

A big, blizzard proved 38 inch wide Snowblower is mounted in seconds. Two-stage, this rugged Snowblower used controlled hurricane-force winds to throw the snow from one foot to fifty feet away.

Gets the drives and walks cleaned fast, with the lugging power from Gravely's high-torque engines on the Gravely 424, Gravely 430 or Gravely 432.

Gravely's famous Swiftamatic 8 transmission gears the ground speed down while the blower speed remains the same for the really tough snowblowing. Open throat design gets the snow out fast without clogging. Big, carbon-steel reel feeds the snow into the fan for maximum efficiency.

All-gear-drive. No belts or chains in the blower mechanism. You use the engine power effectively.

Control the throw from the Driver's seat . . . put the snow exactly where you want it. Deflector on the chute gives even greater control if desired.

Heavy duty welded construction, tough and rugged.



48" SNOWDOZER

Blade used the tractionized power of the rear-engine Gravely 424, 430 and 432 to maximum advantage.

Adjustable 25° left and right, or straight ahead, from the operator's position. Attaches and detaches in less than a minute after the permanently mounted rear axle brackets are in place. Height adjustable by use of position lock, adjustable skids standard.

Heavy duty A-frame construction. Special reinforced spring-trip blade for maximum protection of tractor and operator.



MANUFACTURER'S SPECIFICATIONS AND RECOMMENDATIONS

ENGINE 424 430 432

Type4-cycle, Air cooled
 Horsepower @ 3600 rpm10.....12.....14
 CrankshaftHorizontal
 Number of CylindersOne (1)
 Stroke (in.)2.875.....3.250.....3.250
 Piston Displacement

ValvesMechanical
 BearingsMain Bearings, Precision Ball
 Oil Sump Capacity5 U.S. pints
 Oil SpecificationsAPI—Service MS

ELECTRICAL SYSTEM

Type of StarterElectrical (12 volt)
 Starter MotorBendix type
 MagnetoFlywheel
 Spark PlugChampion H-10, gap—.025 in.
 HeadlightsThree 12 volt Bulbs
 TaillightsTwo 12 volt Bulbs

FUEL SYSTEM

CarburetorSingle Float
 Fuel Tank Capacity5.0 U.S. Gallons
 Filler CapVented Type
 Fuel GradeRegular 90 octane or higher
 FilterMesh type located in tank
 Air CleanerDry, single element
 ChokeManual
 Fuel PumpAutomotive Diaphragm type

TRANSMISSION

TypePlanetary Gear
 Clutch typeFriction Cone
 EP-90 Transmission Capacity5 U.S. Quarts
 Drive TrainAll Gear
 Speeds Forward4
 Speeds Reverse4
 Oil RecommendationsSAE 90W EP

GENERAL DATA

SteeringBevel Gear
 Steering Ratio7.2 to 1
 Steering Lubrication4 Alemite grease fittings
 Rear Tire Size23—8.50 x 12
 Rear Tire Pressure12 psi
 Front Tire Size16—6.50 x 8
 Front Tire Pressure12 psi
 Front Wheel bearingsInner and outer ball bearings
 Front Wheel Lubrication2 Alemite grease fittings
 Wheel base46 inches
 Tread Width—Front30½ inches
 Tread Width—Rear28 inches
 Outside Turning Radius87 inches (L&R)
 Length75½ inches
 Width36¼ inches
 Height43 inches
 Ground Clearance—front axle10 inches
 Ground Clearance—rear axle6¾ inches
 Shipping Weight900
 Type of brakesBand (Individual Wheel)
 Parking BrakesBand (Individual Wheel)
 Speed Range, mph0-4

To continue its program of quality and design improvement, the manufacturer reserves the right to change specifications, designs or prices without notice and without incurring obligation.

To continue its program of quality and design improvement, the manufacturer reserves the right to change specifications, design or prices without notice and without incurring obligation.

FORM NO. 14535P1 - 5M 9-69

PRINTED IN UNITED STATES OF AMERICA